

Coanda Water Intake

Basics

Introduction

The Coanda Intake is a self-cleaning type of water Intake. It uses a tilted wedge-wire screen partly down an Ogee-shaped slope (Fig 11). A solid acceleration plate forms the ogee slope above the screen and creates the high sweeping velocities necessary for self cleaning.

The simplest type of wedge-wire screen is flat wedge-wire (Fig 1). The wedge-shaped wires are welded onto backing rods below the screen.

The close spacing of the wires (slot opening) allows the fluid to pass while stopping solids. Depending on the slot opening, Coanda intakes will reliably screen out 1.0mm debris with minimal maintenance. Wedge wire screens are widely used in industry.

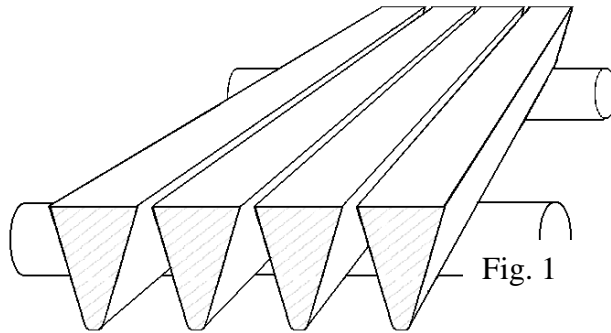

Fig. 1

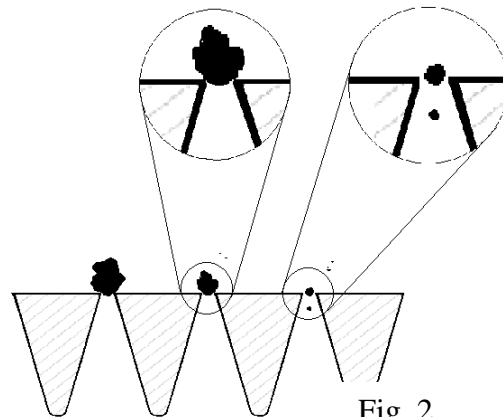

Fig. 2

How they work

Figure 2 shows how a Wedge-wire screen will stop all particles larger than the slot opening. As the fluid passes through the screen, the slot opening gets larger (due to the wedge shape of the wires). Particles larger than the slot openings can have only two points of contact with the wedge-wires (Fig 2). The two points of contact combined with the inward-opening of the slots make it difficult for anything to get stuck.

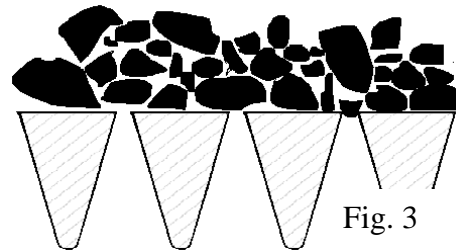

Fig. 3

Debris and screens

When screens are oriented flat, the screened-out debris will collect on top (Fig. 3). Although the screen openings would still not plug, the depth of debris would slow the flow of water through the screen.

Screen Slope

In order to keep the top area free from debris, the screens are installed on a slope (Fig. 4). Some of the water flows through the slot openings and some of the water sweeps debris down the screen. Coanda Intakes need minimum water-speeds across the screens for sweeping debris off.

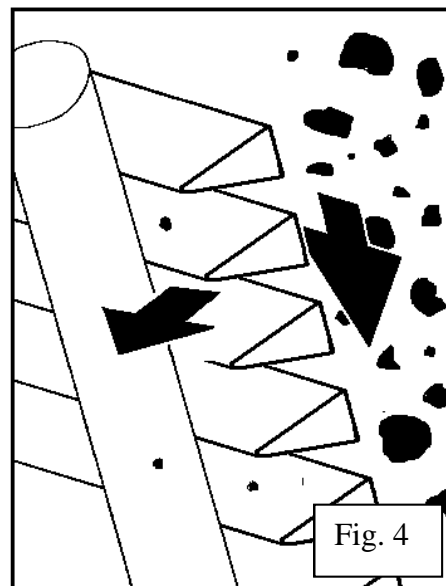

Fig. 4

Acceleration Plate

The acceleration plate drop (H_a) (Fig 5) creates the minimum water speeds needed for self cleaning. The acceleration plate is a solid smooth plate above the screen. The acceleration plate also smoothes the water and delivers the smooth, accelerated water to the screen at the correct angle.

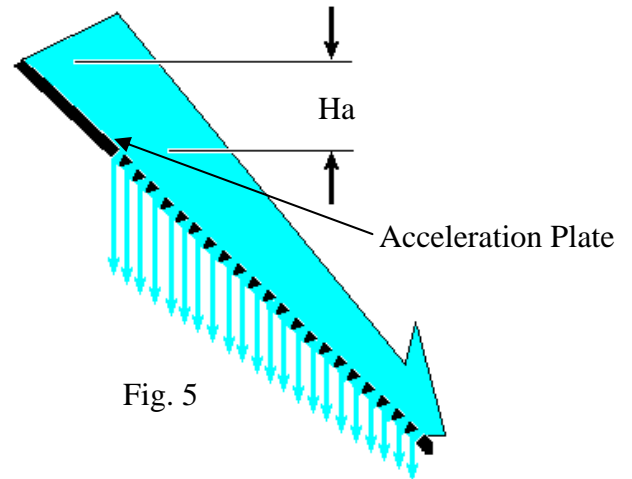

Fig. 5

Flat Wedge-wire

The wedge-wire screens shown thus far are Flat Wedge-wire. The weight (depth) of water above the screen pushes the water through the slot openings. This is called Orifice flow (Fig 6). When a flat wedge-wire screen is sloped to shed debris, the flow speed across the screen increases, and the orifice flow (through the screen) decreases. The high sweeping velocity Coanda intakes need for self cleaning results in less flow through the flat-wire screens.

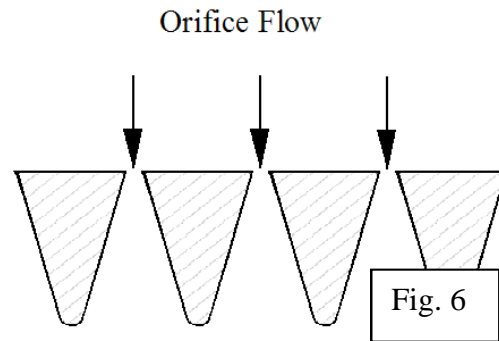

Fig. 6

Tilted Wedge wire

The solution for high velocities vs. screen flow, is to use Tilted Wedge-wire. Tilted Wedge-wire screens use the same wedge-shaped wires as flat screen. The difference is the tilt of each wire. The wires are welded to the backing rods on a tilt. The leading edge of each wedge-wire sticks up into the flow (Fig 7), and cuts a section of water above it (Fig 8). This is called Shearing flow. As the water speed across the screen increases, shearing flow (through the screen) also increases. Figure 8 shows the flow difference where water is flowing across the face of the two types of screen. This difference is much greater as the water speed increases across the screen face.

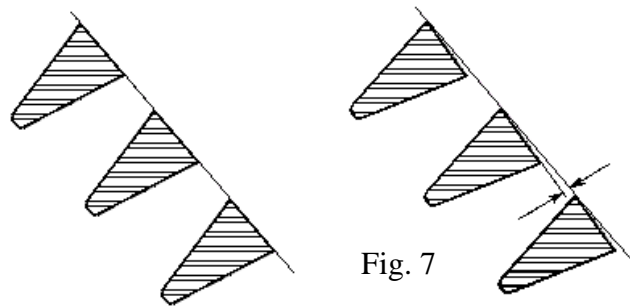

Fig. 7

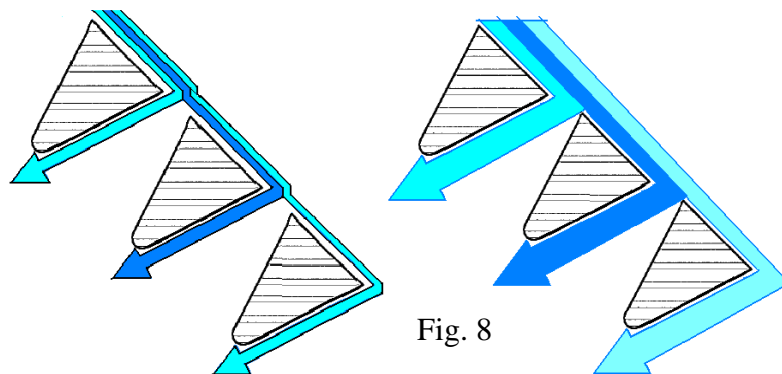

Fig. 8

For this reason, all Coanda Intakes use Tilted wedge-wire screens and high sweeping velocities across the face of the screens.

Water flow through the intake

Water flows through the tilt wire screen into a collection chamber underneath (Fig 9). The collection chamber flows into a stilling chamber (not shown) then into a pipe (penstock). The wedge-wire screen keeps debris above the screen and allows it to be swept downstream.

On most creeks and rivers the amount of debris in the water is minimal during low flow times. Larger amounts of debris occur during spring runoff or after heavy rains. At these times there is also excess water to sweep the debris off of the screens and carry it downstream.

Screen approach

A properly designed acceleration plate ensures that smooth water (at the appropriate speed) meets the screen at the correct angle. When the water reaches the screen with laminar flow and the correct minimum speed, screens will perform to their capacity.

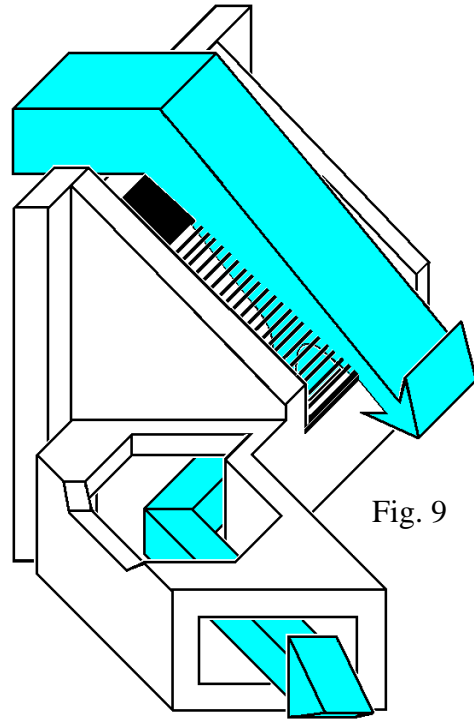
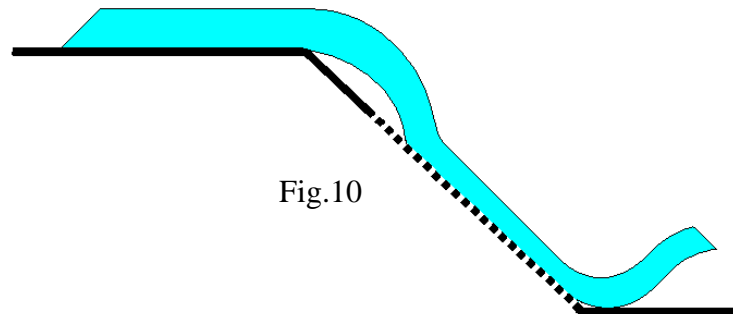
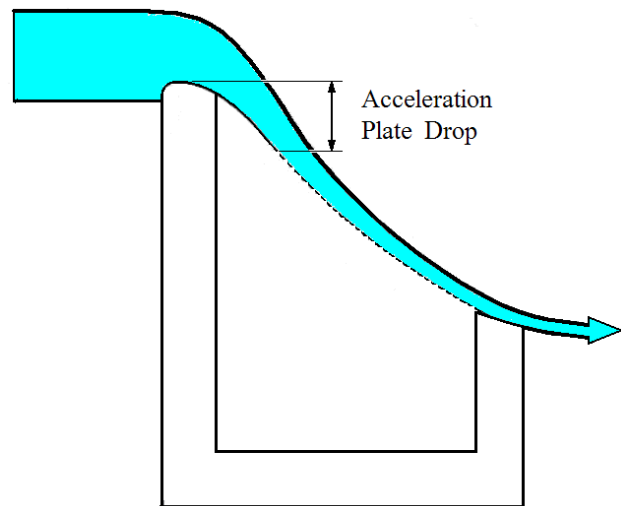

Figure 10 shows an intake profile with flow problems. The paths onto and off the screen are sharp. The water flow is unstable, turbulent and the water misses the top screen section. Screen performance will suffer as a consequence of this design. The unstable water flow off the screen will also erode the stream bed below the intake.



A proper approach and exit is shown in Figure 11. The top of the front wall (weir) and the acceleration plate form a smooth approach onto a curved screen. As the water flows down the acceleration plate it becomes smooth and fast. The discharge water (off the bottom of the screen) is close to level. The acceleration plate drop and curvature are designed for the site conditions of the intake.



Site Design

Figure 12 shows a Coanda Intake design for a narrow site with deep, fast-flowing water. The acceleration plate has a longer radius and surface length. The screen has a longer surface length also.

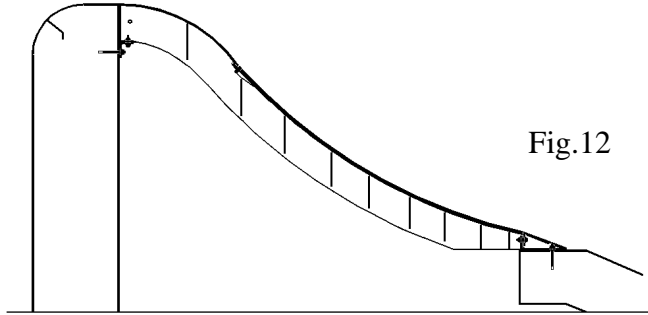

Fig.12

Some intake sites have large boulders in the water during floods. The intakes designed for these locations use thicker metal for the construction, heavier screens, and bars welded to the top of the screens (as well as other features).

Conclusion

Coanda Intakes have been in operation for over 25 years. They are well proven to self clean using fine slot openings. The Coanda intake is a cost-effective, low-maintenance method of excluding fine debris at the intake itself.

Most Coanda intakes are custom designed for each site.

This pamphlet is a short introduction to the technology.

Please contact the author for more in-depth information.

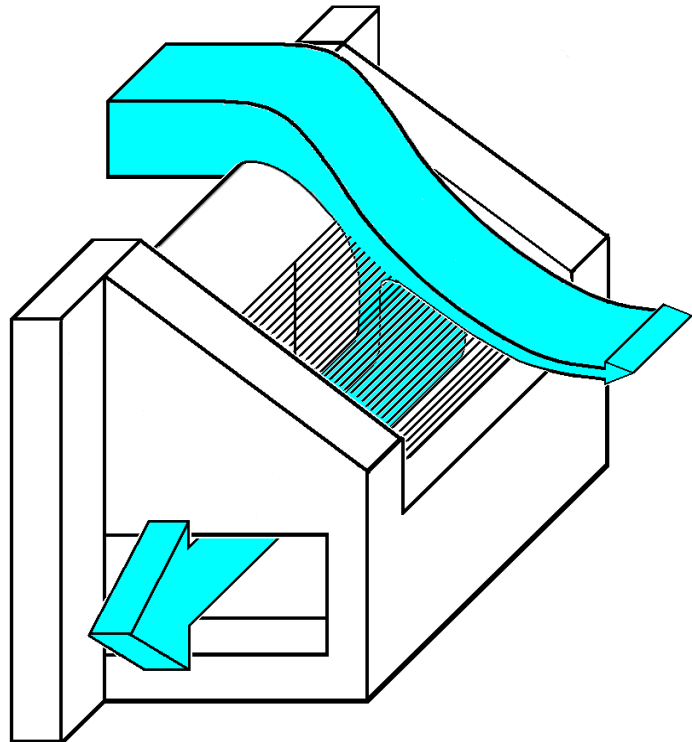

Author

The author has worked on Coanda Intake design since 1998.

Stuart Douglass

Coanda Intakes, Ltd.

164 Bestwick Drive,

Kamloops B.C. Canada, V2C-1M8

Phone: 250-828-1110

Fax: 250-828-1133

Cell: 250-318-6050

stuartd@coandaintakes.com

www.coandaintakes.com

